

Kräus[®]

INSTALLATION GUIDE

Ramus[™] Single Handle Basin Faucet

KBF-1221

Congratulations on the purchase of your new Kraus® plumbing fixture!

Please keep the box and packaging materials until your product is completely installed. If you have any questions, require technical assistance, or have any problems with your product:



DO NOT RETURN TO STORE

Please contact our Customer Service Team

1-800-775-0703 / customerservice@kraususa.com

Have the model number available, and retain a copy of your receipt with purchase date for reference.

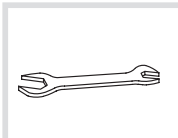
If for any reason this product does not meet your expectations, please be sure to repack this product in the original box and packaging material to avoid damage during transit.

STOP

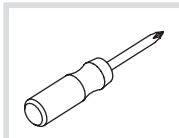
Prior to Installation:

- Make sure you have all necessary parts by checking the diagram and parts list. If any part is missing or damaged, please contact Kraus® Customer Service at 800-775-0703 for a replacement
- Read all instructions and safety warnings and ensure you have all tools, parts, and equipment necessary for a safe installation.
- Turn off the hot and cold water lines at the angle stops and turn on the old faucet to release any built-up pressure
- Pre-drilled countertop hole size requirement: 1-3/8"(min)
- Max countertop thickness: 2 5/8"

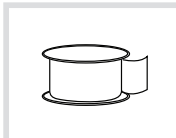
Tools you will need:



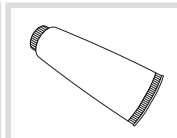
Wrench



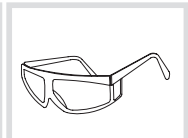
Phillips Screwdriver



Pipe Tape



Silicone Sealant
(optional)



Safety Goggles

Care & Maintenance

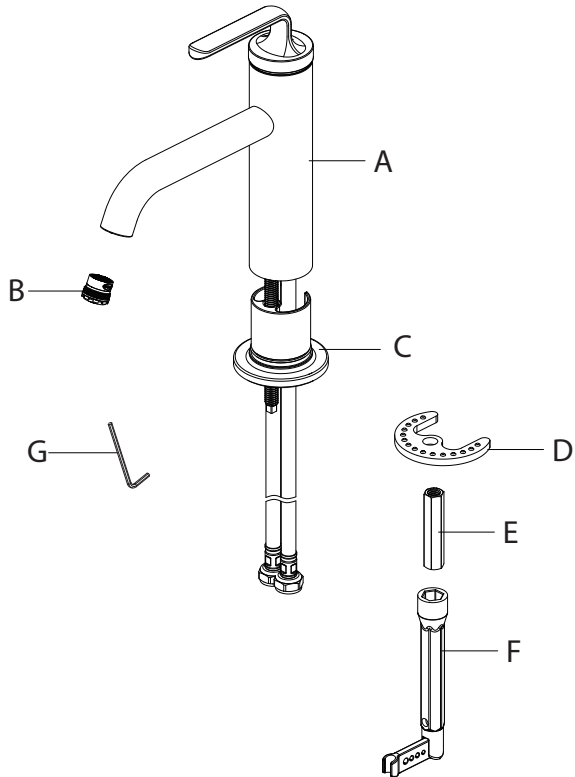
* To keep the product clean & shining, follow the steps below:

1. Rinse with clean water & dry with a soft cloth
2. Do not clean with soaps, acid, polish, abrasives or harsh cleaners
3. Do not use cloth with a coarse surface
4. Unscrew the aerator and clean when necessary

* This installation manual is subject to change without further notice.

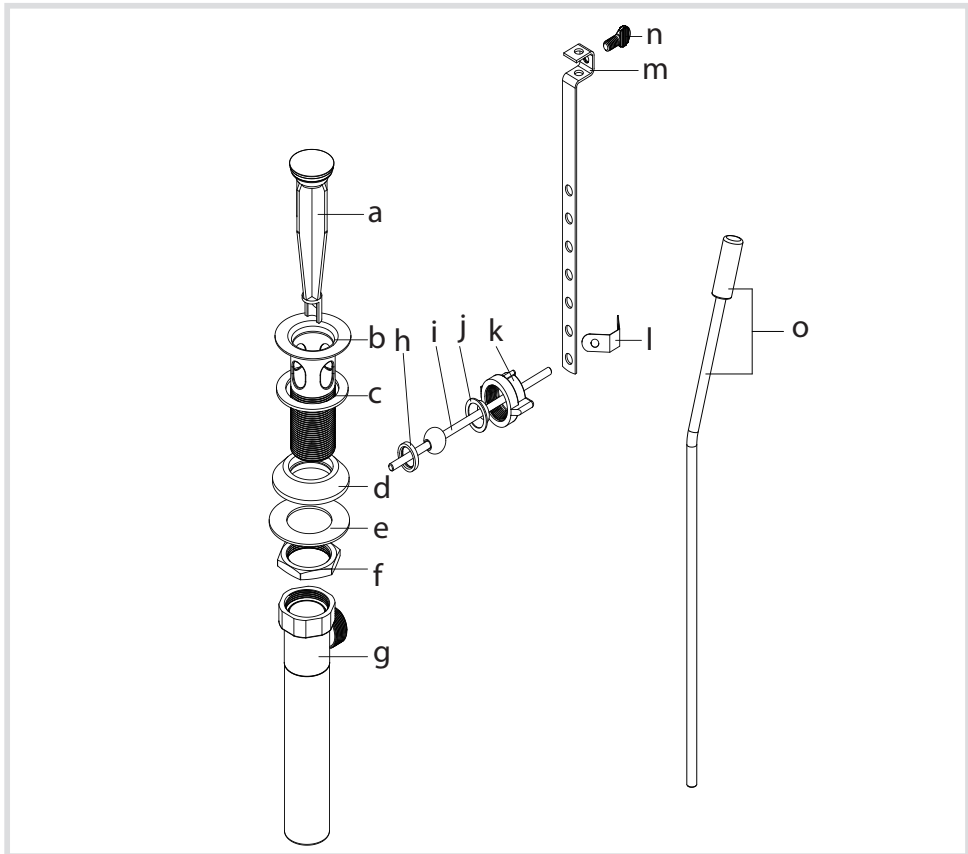


Diagram and Parts List



- A. Faucet Body
- B. Aerator
- C. Flange
- D. Metal Washer
- E. Lock Nut
- F. Spanner Key
- G. Hex Wrench

Diagram and Parts List-Lift Rod Drain

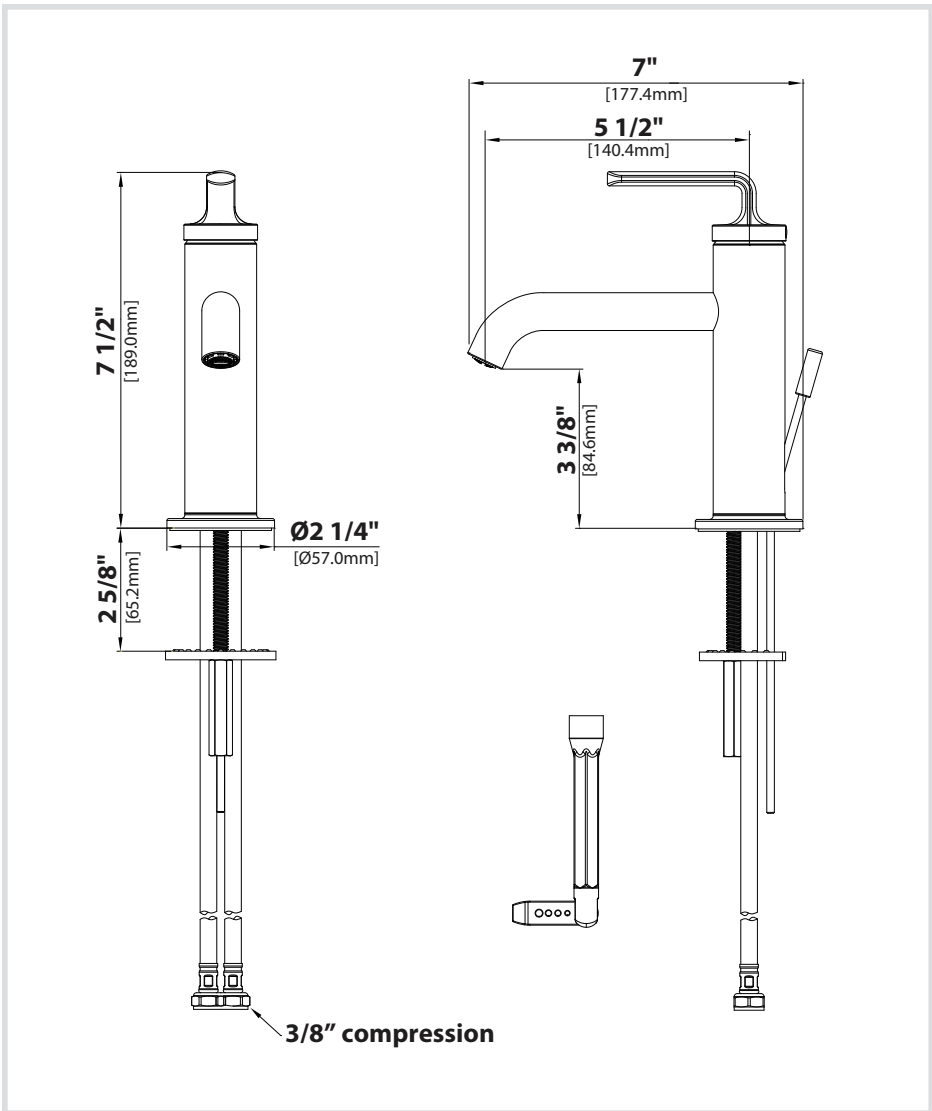


a. Waste Stopper
 b. Drain Flange
 c. Rubber Washer
 d. Concave Washer
 e. Metal Washer

f. Mounting Nut
 g. Tail Pipe
 h. Top Hat Washer
 i. Drain Off Pole
 j. Washer

k. Retaining Nut
 l. Clip
 m. Extender Rod
 n. Thumb Screw
 o. Lift Rod

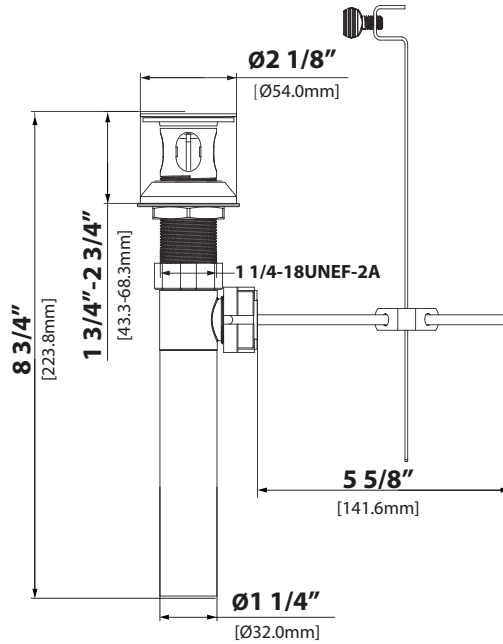
Faucet Dimension



Installer Tip:

Shut off main water supply before installing new faucet

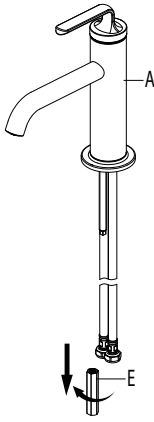
Drain Dimension



Installer Tip:

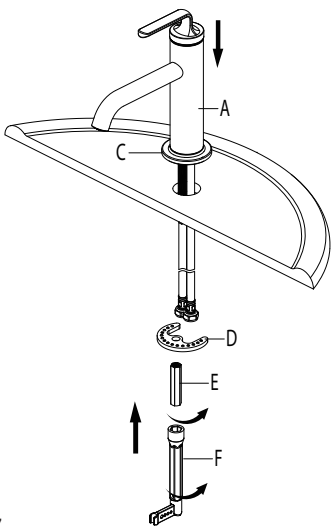
Shut off main water supply before installing new faucet

Step 1: Remove lock nut

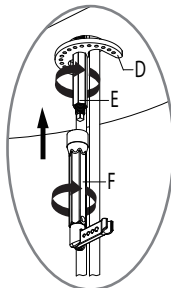


Shut off the water supply.
Remove the lock nut (E) from the faucet (A).

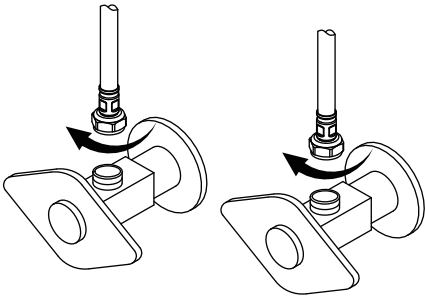
Step 2: Installing the faucet



Before installation, ensure that the flange (C) is placed on the bottom of the new faucet (A). Place faucet (A) through the hole in sink. Secure the faucet (A) to the sink using the metal washer (D) and lock nut (E) provided. Tighten lock nut (E) with spanner key (F) provided. Ensure the metal washer (D) and hoses are no interference.



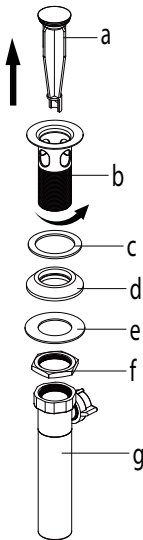
Step 3: Connect waterlines to main valve



Attach waterlines to angle stops and tighten until snug. Turn on angles stops and check for leaks (DO NOT TURN FAUCET ON)

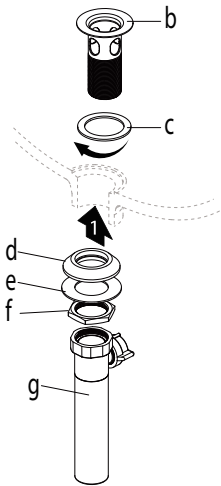
NOTE: Please make sure filter washers are installed before connecting to the main valve.

Step 4A: Installing the drain



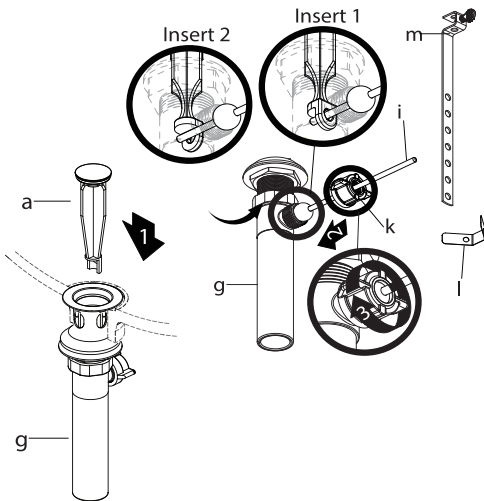
Remove waste stopper (a) and drain flange (b) from tailpipe (g). Remove concave washer (d), metal washer (e) and mounting nut (f) from drain flange (b).

Step 4B: Installing the drain



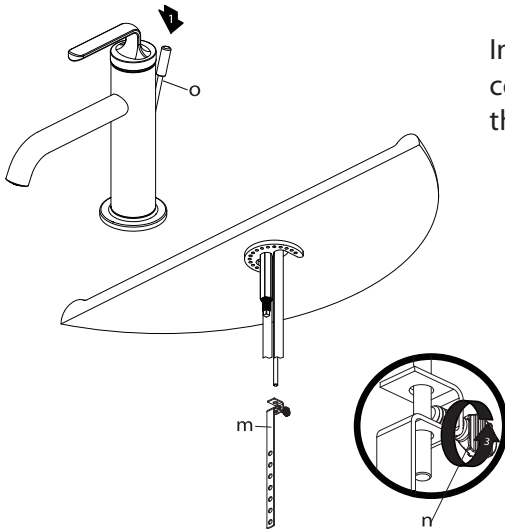
Insert drain flange (b) through drain hole with rubber washer (c) attached. From underneath, place concave (d) and metal washer (e) on drain flange. Secure with mounting nut (f). Thread tailpipe (g) onto drain (b) and hand tighten.

Step 4C: Installing the drain



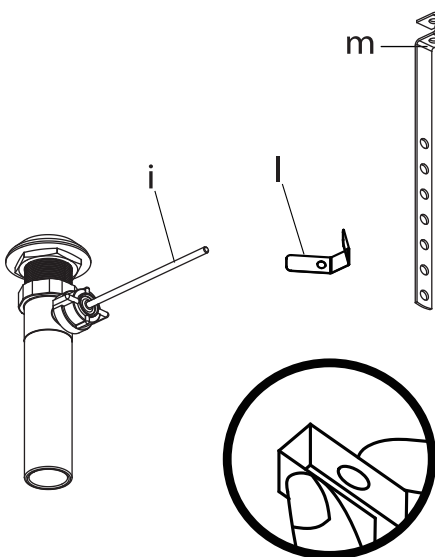
Insert waste stopper (a) into drain flange. Remove extender rod (m) and clip (l) from drain off pole (i). Remove nut (k). Insert drain off pole (i) into drain pole opening of tailpipe (g). See insert 1. Secure nut (k) to drain off pole opening of tailpipe (g).

Step 4D: Installing the drain



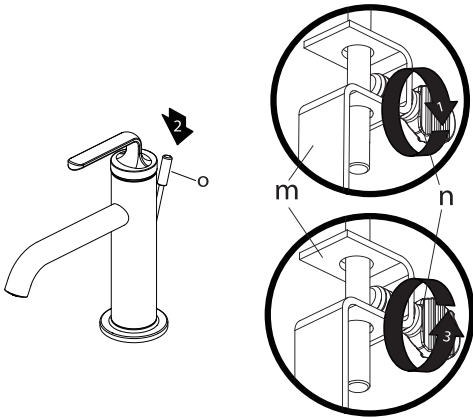
Insert lift rod (o) through spout and connect with extender rod (m). Tighten thumb screw (n).

Step 4E: Installing the drain



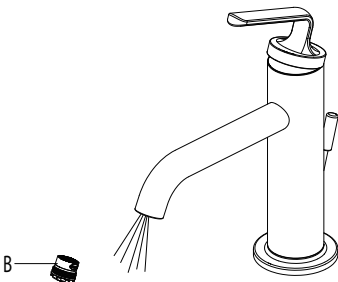
Attach drain off pole (i) to extender rod (m) with clip (l).

Step 4F: Installing the drain



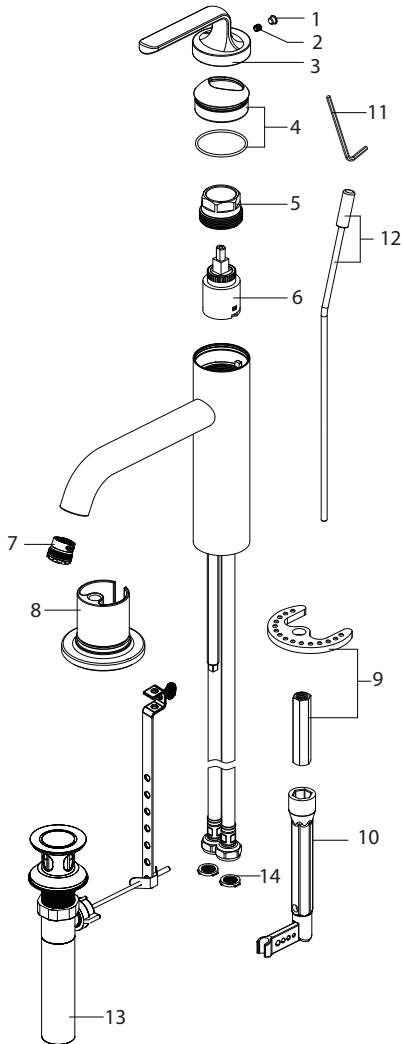
Loosen thumb screw (n) on extender rod (m). Push down on lift rod (o) until stopper is in open position. Retighten thumb screw (n).

Step 5: Flush faucet



After installing faucet, remove aerator (B) with a coin. Turn water on for 30 seconds to remove any debris. Reassemble aerator (B).

Replacement Parts



Replacement Parts List	Finish / Color	Part #
1. Cover Button	GR, BL*	KP27159
2. Set Screw		KP27158
3. Handle	SFS, MB, GM, BG, SFSB*	KP27157
4. Cap & O-ring	SFS, MB, GM, BG, SFSB*	KP27160
5. Bonnet Nut		KP27161
6. Cartridge		KP27162
7. Aerator		KP27163
8. Flange	SFS, MB, GM, BG, SFSB*	KP27206
9. Metal Washer & Nut		KP27225
10. Spanner Key		KP27144
11. Hex Wrench		KP27166
12. Lift Rod	SFS, MB, GM, BG, SFSB*	KP27165
13. Drain Assemble	SFS, MB, GM, BG, SFSB*	KP27019
14. Filter Washer		KP27167

*Denotes faucet component color options:

SFS - Spot Free Stainless Steel
 MB - Matte Black
 GM - Gunmetal
 BG - Brushed Gold
 SFSB - Spot Free Black Stainless
 GR - Grey
 BL - Black

Troubleshooting

If you have followed the instructions carefully and your faucet still does not work properly, take the following coorrective steps:

PROBLEM	CAUSE	ACTION
Leakage under the handle	Bonnet nut (5) has come loose	Remove the cover button (1). Loosen set screw (2) with hex wrench (11). Remove the handle (3). Unscrew cap (4) (by hand only). Tighten bonnet nut (5) with an adjustable wrench
Aerator drips or has inconsistent water flow pattern	Aerator (7) is dirty or not seated properly	Unscrew aerator (7) with a coin and clean out debris
Water will not shut off completely	Cartridge may need to be adjusted or replaced	Remove the cover button (1). Loosen set screw (2) with hex wrench (11). Remove the handle (3). Unscrew cap (4) (by hand only). Tighten bonnet nut (5) with an adjustable wrench. Remove the cartridge (6). Check for cracks
There is leaking from the sink drain at the base of the sink.	The sink has a rough or irregular surface.	Apply additional silicone sealant to the beveled side of the drain flange. Retighten and test for leaks
There is a low flow of water.	The filter washer in the hose connectors is dirty.	Turn off the water supply at water valve and unscrew the hose connectors from water supply lines. Clean the filter washer in the water lines with hot water, removing any debris or calcium build up

Codes/Standards Applicable:



NSF / ANSI 61



ASME A112.18.1
1.2GPM 4.5L/min maximum

Faucet - Lifetime Limited Warranty

Kraus® USA Plumbing, LLC ("Kraus") extends this warranty to the original purchaser for personal household use of the Faucet when purchased from an authorized Kraus dealer and in the location of original installation. This warranty is non-transferable.

Kraus warrants the structure and finish of the Faucet to be free from defects in material and workmanship under normal usage for as long as the original purchaser resides in the residence in which the Faucet was first installed.

Kraus warrants the Faucet's sprayhead assembly (including the engine, aerators, structure, restrictors, back flow preventers, sprayer hoses, braided supply line hoses which encompasses nylon, silicon and stainless steel) of the product to be free from defects in material and workmanship under normal usage for a period of one (1) year from the date of purchase.

Kraus warrants the Faucet's cartridge to be free from defects in material and workmanship under normal usage for a period of five (5) years from the date of purchase.

Any product reported to the authorized dealer or to Kraus as being defective within the warranty period will be repaired or replaced with a product of equal value at the option of Kraus.

Commercial Warranty

Kraus USA Plumbing, LLC ("Kraus") warrants its Products for a period of one (1) year to commercial purchasers of Products used in industrial, commercial and business applications.

Care and Cleaning Instructions

Certain cleaning products may cause damage to a Product's finish and use of the following on the Product will void this warranty:

- Abrasive cleaners such as powders, bleach, ammonia, alcohol or chlorine
- Abrasive pads, steel wool or wire brushes

What is Not Covered

This warranty does not cover Products that were discontinued when purchased or display Products, whether such Products were purchased at discount outlets, unauthorized dealers, and/or sold on clearance. This warranty does not cover any free gifts included with purchase.

This warranty does not cover damage resulting from neglect, misuse (including use for an unintended application), abuse, carelessness, accident, hard water or mineral deposits, exposure to corrosive materials, improper maintenance, alteration of the Product, or failure to follow care, cleaning or installation instructions enclosed with your Product. Kraus recommends that all Kraus Products be installed by a fully licensed and insured trade professional with experience in the installation of bathroom and/or kitchen manufactured goods.

How to Make a Warranty Claim

If you are a **consumer purchaser**, please contact a Kraus® Customer Service Representative at:
Kraus USA Plumbing, LLC
12 Harbor Park Drive
Port Washington, NY 11050
Toll-free 800-775-0703
Customerservice@kraususa.com

If you are a **plumbing contractor or trade professional**, please contact a Kraus Pro Representative at:
Kraus USA Plumbing, LLC
12 Harbor Park Drive
Port Washington, NY 11050
516-801-8955
Proservice@kraususa.com

If you are an **authorized partner**, please contact a Partner Support Representative at:
Kraus USA Plumbing, LLC
12 Harbor Park Drive
Port Washington, NY 11050
516-801-8954
Partnersupport@kraususa.com

In requesting warranty service, please be ready to provide your proof of purchase and a description of the problem. Shipping charges will be covered for the first (1) year of the warranted replacement part or product (HI, AK, and Puerto Rico shipping charges may apply). International shipping fees are not included.

Limitation on Duration of Implied Warranties

Please note that some states/provinces (including Quebec) do not allow limitations on how long an implied warranty lasts, so the below limitations may not apply to you. TO THE MAXIMUM EXTENT PERMITTED BY APPLICABLE LAW, ANY IMPLIED WARRANTY, INCLUDING THE IMPLIED WARRANTIES OF MERCHANTABILITY AND OF FITNESS FOR A PARTICULAR PURPOSE, IS LIMITED TO THE STATUTORY PERIOD OR THE DURATION OF THIS WARRANTY, WHICHEVER IS SHORTER.

Limitation of Special, Incidental or Consequential Damages

Please note that some states/provinces (including Quebec) do not allow the exclusion or limitation of special, incidental or consequential damages, so the below limitations and exclusions may not apply to you. TO THE MAXIMUM EXTENT PERMITTED BY APPLICABLE LAW, THIS WARRANTY DOES NOT COVER, AND KRAUS USA PLUMBING, LLC SHALL NOT BE LIABLE FOR, ANY SPECIAL, INCIDENTAL OR CONSEQUENTIAL DAMAGES (INCLUDING LABOR CHARGES TO REPAIR, REPLACE, INSTALL OR REMOVE THIS PRODUCT), WHETHER ARISING OUT OF BREACH OF ANY EXPRESS OR IMPLIED WARRANTY, BREACH OF CONTRACT, TORT, OR OTHERWISE.

This warranty gives you specific legal rights, and you may also have other rights which vary from state/province to state/province.

Download the Kraus Care & Maintenance Guide at:
<http://www.kraususa.com/maintenance>

IMPORTANT

Register Your Kraus Product

Activate Your Warranty

Access Premium Customer Support

Get Product Information

REGISTER TODAY

<http://www.kraususa.com/registration>



Kräus[®]
www.kraususa.com